

Domestic & Commercial
SE Range



Axial Flow **Fans**

features & benefits



SE range

The SE “Executive” Axial Range is a stylish range of slim profile axial flow fans which provides powerful extract of air through windows, walls, ceilings and panels for a variety of domestic and commercial applications.

- 3 standard sizes from 100mm to 150mm.
- Air volume flow rates of up to 0.088 m³/s (317 m³/hr).
- Static pressures of up to 80 Pa.
- Axial impeller design for larger volumes.
- IPX4 – Splash proof.
- Shock proof, heat resistant plastic.
- Suitable for operating temperatures up to 40°C.
- Motors are double insulated with built-in thermal overload protection.
- CE Marked and BEAB approved.
- Sealed for life ball bearings to operate at any angle.
- Timer models adjustable from 3-15 minutes.
- Front plate fascia protrudes between 8mm and 15mm dependant on model, providing one of the slimmest profile fans on the market
- Lower noise levels.

Features & Benefits

Motor protection – Each SE motor is double insulated so no earth is required with integral thermal overload protection which prevents the motor from overheating.

Range - There are three sizes, 100mm, 125mm and 150mm.

Options - The SE range, dependant on model, incorporate a run on timer adjustable between 3 and 15 minutes; a dynamic type humidistat with anti-hunting feature; and can be operated via a pull cord.

Safety – SE fans are IPX4 Splash proof, protected against water splashing from all directions which means they can be safely installed in Zones I and II in accordance with IEE Wiring Regulations.

Ease of installation – Designed and supplied with all the necessary fixings, with unique features to make installation easier.

Material strength - Units are manufactured from shock proof, heat resistant white plastic, which is durable and non corrosive.

Mounting – Each unit is suitable for window, wall, panel or ceiling mounting installations.

Full ancillary range – Wall kits, window kits, fan locking rings.

Reliability – Motors have sealed for life bearings.

Warranty – Each SA has a 2 year warranty.

Applications

Shower rooms, bathrooms, kitchens, utility rooms, residential and commercial facilities.

product information



SE range

Product Code	Description
SE100	Basic unit, fan only
SE100T	Run on timer unit
SE100C	Pull cord operated unit
SE100HT	Humidistat, timer and neon light unit
SE125	Basic unit, fan only
SE125T	Run on timer unit
SE125C	Pull cord operated unit
SE125HT	Humidistat, timer and neon light unit
SE150 B	Basic unit, fan only
SE150T	Run on timer unit
SE150C	Pull cord operated unit
SE150HT	Humidistat, timer and neon light unit

Product Code	Voltage	Maximum Volume		Mounting Arrangement			Operation						
		l/sec	m ³ /hr	Ceiling	Wall	Window	Fan Only	Pull Cord	Run on Timer	Electric Shutter	Humidistat	PIR	
SE100	230	27	97	√	√	√	√						
SE100T	230	27	97	√	√	√	√		√				
SE100C	230	27	97	√	√	√	√	√					
SE100HT	230	27	97	√	√	√	√		√			√	
SE125	230	53	191	√	√		√						
SE125T	230	53	191	√	√		√		√				
SE125C	230	53	191	√	√		√	√					
SE125HT	230	53	191	√	√		√		√			√	
SE150	230	88	317	√	√		√						
SE150T	230	88	317	√	√		√		√				
SE150C	230	88	317	√	√		√	√					
SE150HT	230	88	317	√	√		√		√			√	

Note: The SE Range is not suitable for Duct or Roof mounting

dimensional data

SE range

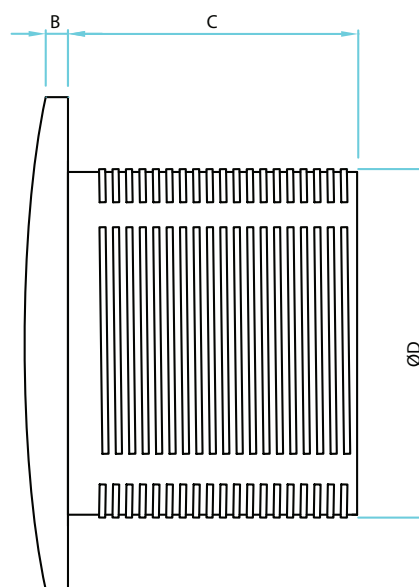
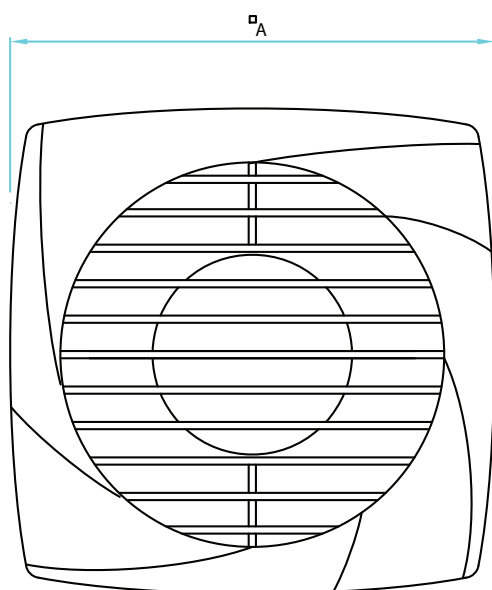

Product Code	A	B	C	D	Weight kg
SE100	140	8	98	98	1.0
SE125	170	15	45	100	1.2
SE150	190	15	60	112	1.4

SE range

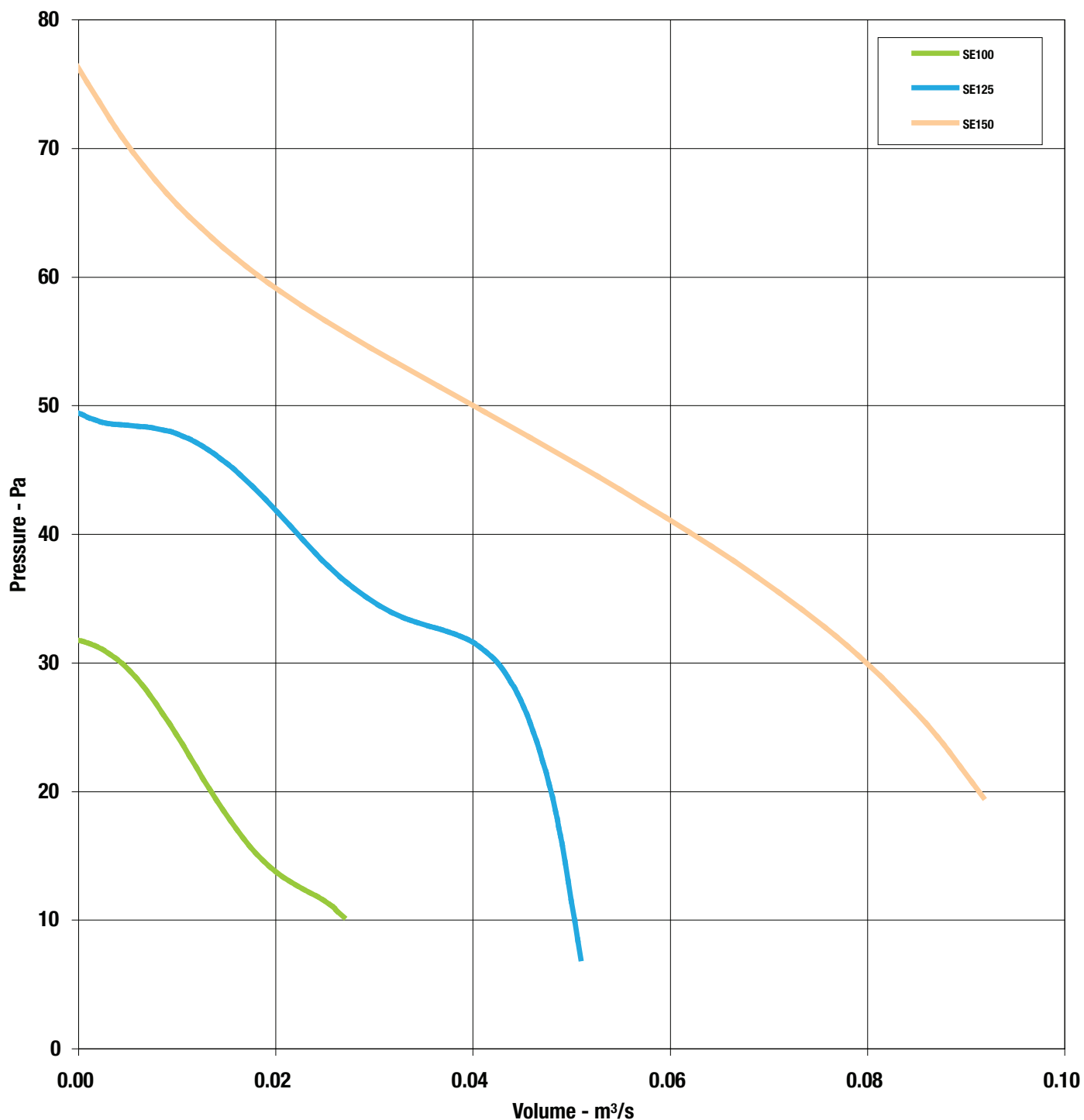

Model	SE100	SE125	SE150
Diameter.	100mm	125mm	150mm
Volts.	230	230	230
Watts.	15	20	25
r/min	2500	2450	2100
l/sec.	27	53	88
Max Pa.	30	50	80
dBA @ 3m	39	41	43

flexible wall sleeve kit



- Comprises durable white plastic grille for external mounting
- 3 metres of pvc flexible duct

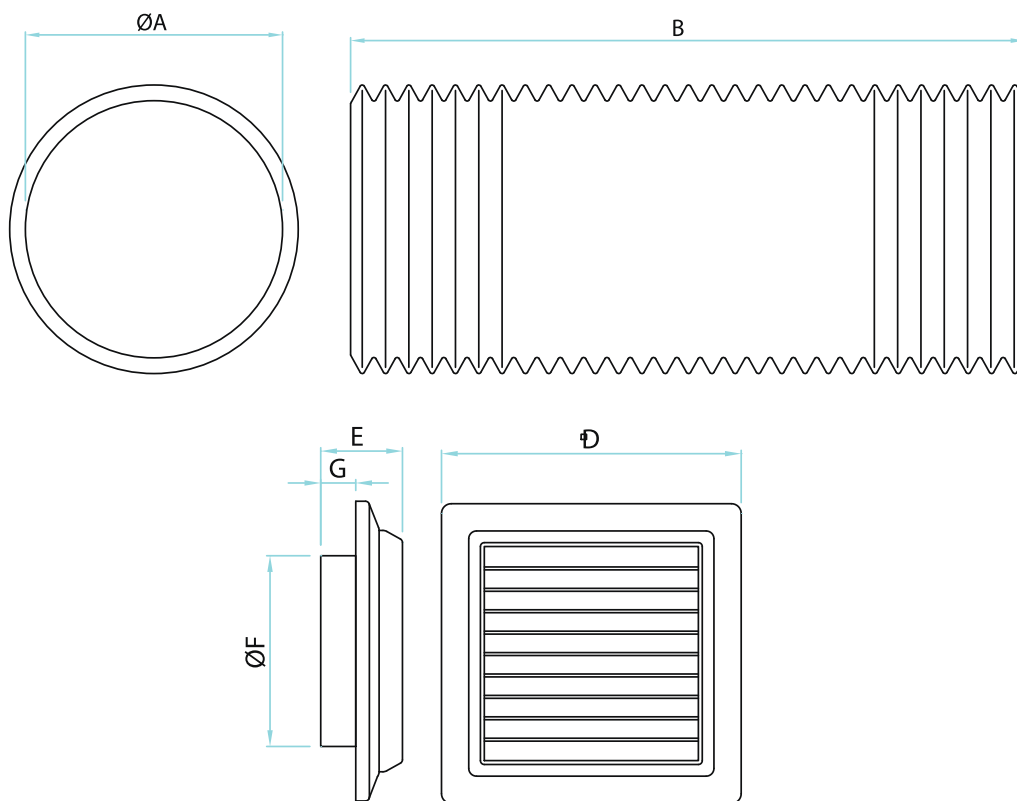

Product Code		A	B	Weight kg		D	E	F	G	Weight kg
SK100SAWKFlex	FLEX 100	100	356	0.305	GRILLE 100	154	42	98	18	0.114
SK125SAWKFlex	FLEX 125	125	356	0.385	GRILLE 125	200	58	123	28	0.210
SK150SAWKFlex	FLEX 150	150	356	0.474	GRILLE 150	200	58	148	28	0.210

accessories

external wall grille

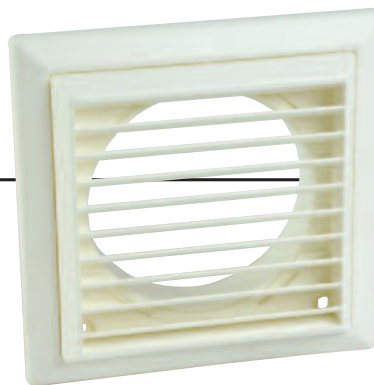

- Durable white plastic
- Mounted independantly of fan

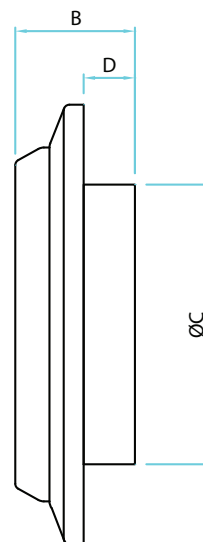
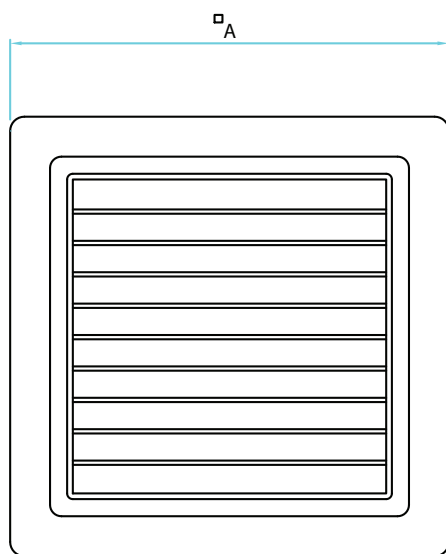

Product Code	A	B	C	D	Weight kg
SKGW-100D	154	42	98	18	0.114
SKGW-125D	200	58	123	28	0.210
SKGW-150D	200	58	148	28	0.210

fan locking ring

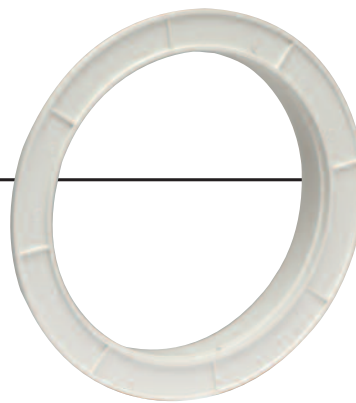

- Durable white plastic
- Fits directly to fan allowing easy installation without fixing screws

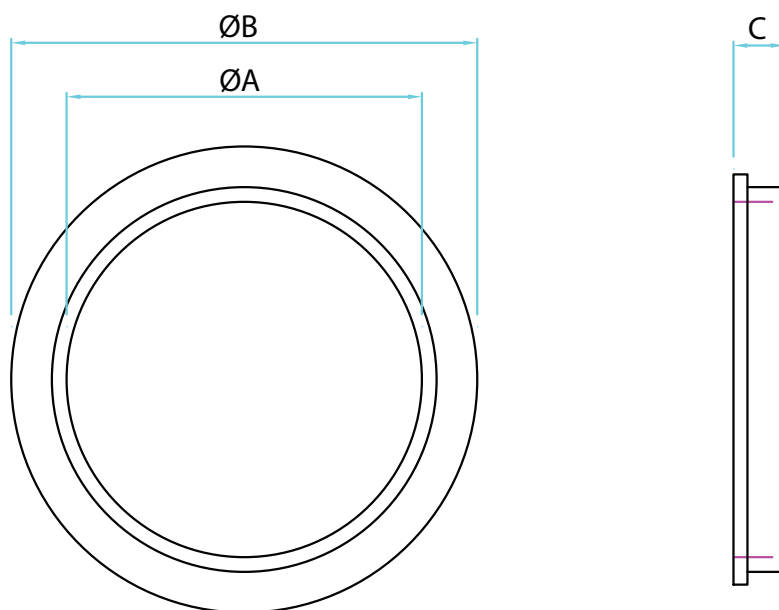

Product Code	A	B	C	Weight kg
SK100SACR	100	132	15	0.048
SK125SACR	125	155	26	0.075
SK150SACR	150	187	26	0.100



- Durable white plastic
- Opens automatically with airflow
- Mounted independently of fan

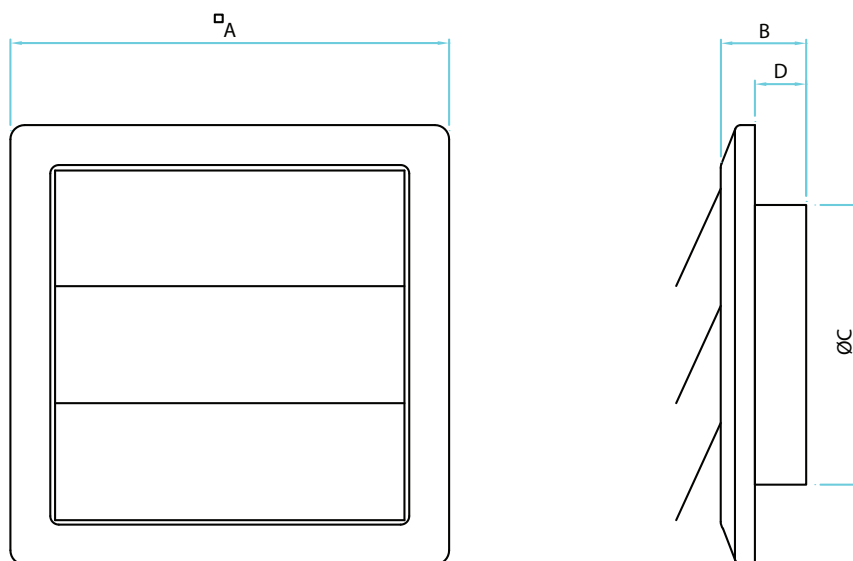

Product Code	A	B	C	D	Weight kg
SKFLW-100D	154	42	98	18	0.078
SKFLW-125D	200	58	123	28	0.178
SKFLW-150D	200	58	148	28	0.182

accessories

telescopic kit



- Durable white plastic grille for external mounting and rigid, white plastic telescopic sleeve.
- Minimum length of 215mm and maximum length of 380mm

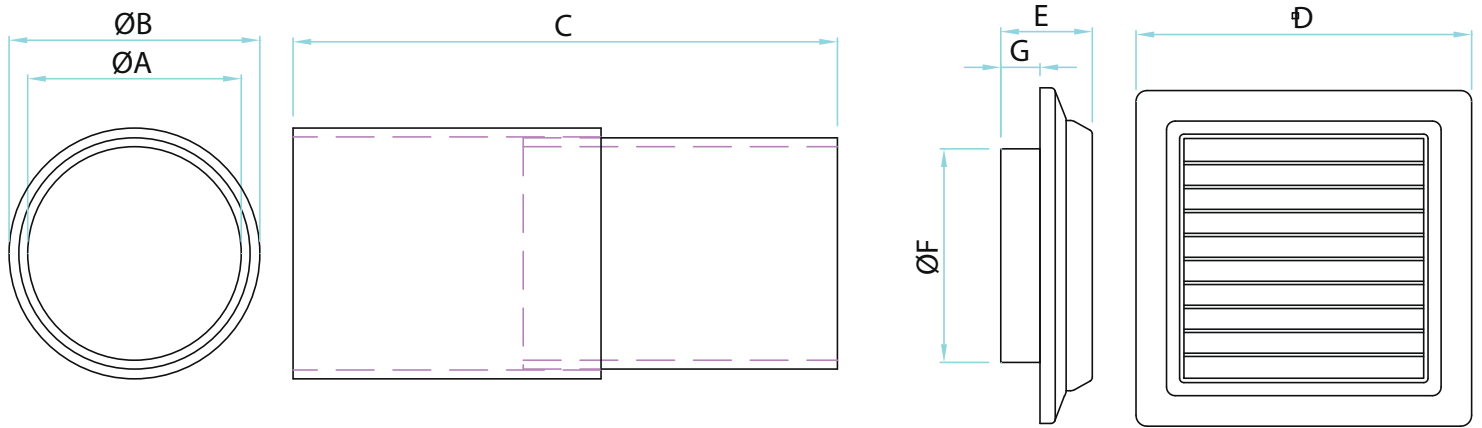

Product Code		A	B	C	Weight kg		D	E	F	G	Weight kg
SK100SAWKTLSCOP	SLEEVE 100	100	105	203/355	0.305	GRILLE 100	154	42	98	18	0.114
SK125SAWKTLSCOP	SLEEVE 125	125	130	203/355	0.385	GRILLE 125	200	58	123	28	0.210
SK150SAWKTLSCOP	SLEEVE 150	150	155	203/355	0.474	GRILLE 150	200	58	148	28	0.210

single glazing kit



- Comprises durable white plastic external grille and ceiling ring
- Allowing easy installation without fixing screws

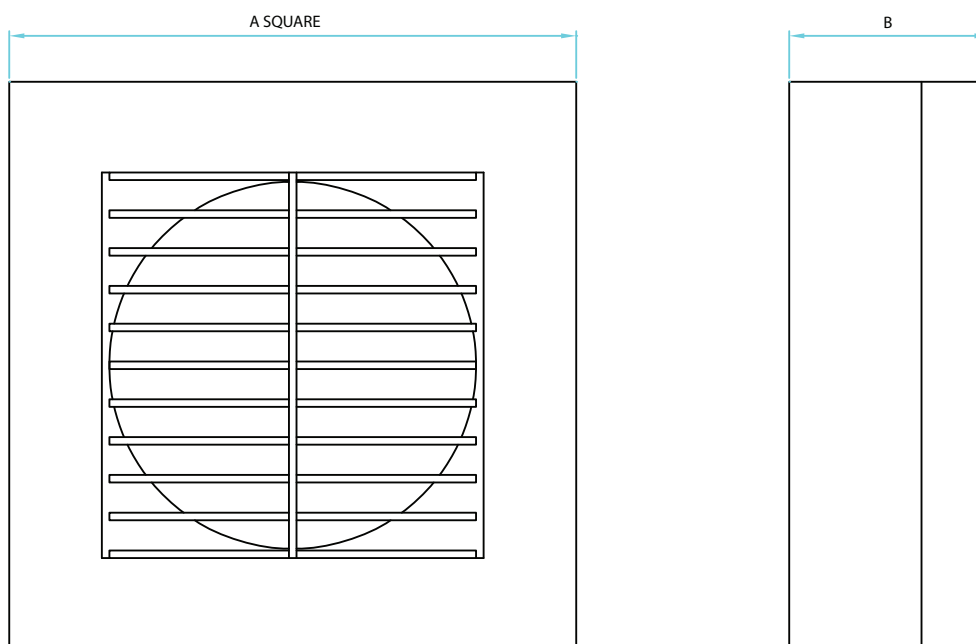

Product Code	A	B	Weight kg
SK100SAWKSG	150	53	0.195
SK120SAWKSG	180	56	0.280
SK150SAWKSG	208	70	0.380

accessories

backdraught shutter



- Durable white plastic
- Opens automatically with airflow
- Mounts directly to fan outlet

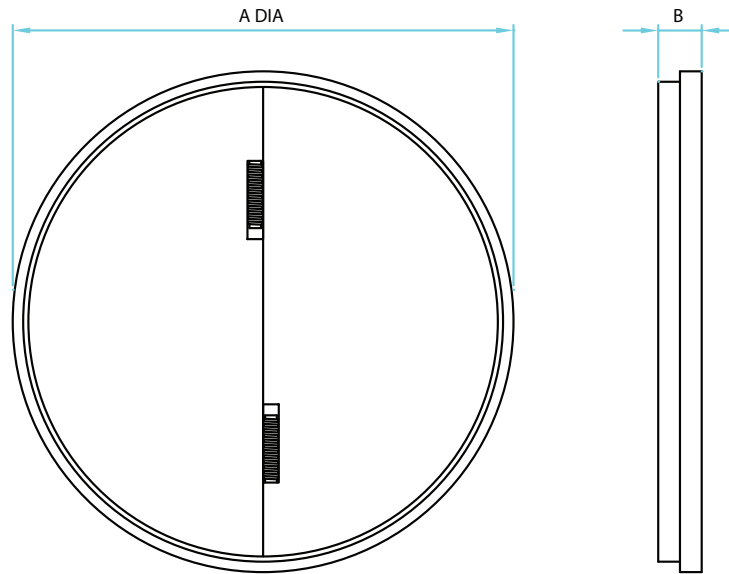

Product Code	A	B	Weight kg
SK100-SEBDS	150	50	0.014
SK125-SEBDS	180	62	0.018

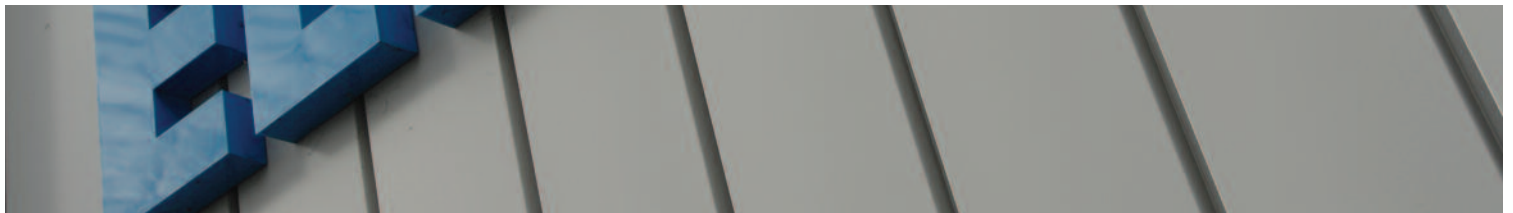

Elta Fans Ltd - Applied Technology

17 Barnes Wallis Road,
Segensworth East Industrial Estate,
Fareham, Hampshire, P015 5ST, United Kingdom.

Visit: eltafans.com

e-mail: mailbox@eltafans.co.uk

Applied Technology:

Tel: +44 (0) 1489 566500

Fax: +44 (0) 1489 566555

Building Services:

Tel: +44 (0) 1384 275800

Fax: +44 (0) 1384 275810

Export:

Tel: +44 (0) 1489 566500

Fax: +44 (0) 1489 566555