

Domestic & Commercial
SCE LV Range



Centrifugal **Fans**

features & benefits

SCE LV range



The SCE LV “Executive” Centrifugal Range is a range of slim profile centrifugal flow fans which have been specifically developed to ensure complete safety in the appropriately regulated “Safety Zones”, offering excellent pressure development characteristics, designed specifically for use with rigid or flexible ductwork for a wide variety of residential and commercial applications.

- 1 standard size 100mm.
- Air volume flow rates of up to 0.036 m³/s (130m³/hr).
- Static pressures of up to 123 Pa.
- Greater pressure capability than axial fans.
- IP57 and Safety Extra Low Voltage.
- Shock proof, heat resistant plastic.
- Suitable for operating temperatures up to 40°C.
- Motors are double insulated with built-in thermal overload protection.
- CE Marked and BEAB approved.
- Sealed for life ball bearings to operate at any angle.
- Supplied complete with Transformer to be mounted in Zone 3.
- Front plate fascia protrudes 19mm, providing one of the slimmest profile fans on the market.
- Timer models adjustable from 3-15 minutes.
- Lower noise levels.
- Anti-vibration gasket between fan casing and wall for quiet operation.
- Supplied with backdraught shutter and inlet cone for improved performance.

Features & Benefits

Motor Protection – Each SCE LV motor is double insulated so no earth is required with integral thermal overload protection which prevents the motor from overheating.

Range - One standard size, 100mm.

Options - The SCE LV range, dependant on model, incorporate a run on timer adjustable between 3 to 15 minutes; a dynamic type humidistat with anti-hunting feature.

Safety – SCE LV fans are IP57 Safe Extra Low Voltage which means they can be safely installed in Zones 0, I and II in accordance with IEE Wiring Regulations.

Ease of installation – Designed and supplied with all the necessary fixings, with unique features to make installation easier.

Material strength - Units are manufactured from shock proof, heat resistant white plastic, which is durable and non corrosive.

Mounting – Each unit is suitable for wall, panel or ceiling mounting installations.

Full ancillary range – Wall kits, fan locking rings.

Reliability – Motors have sealed for life bearings.

Warranty – Each SCE LV has a 2 year warranty.

Applications

Shower rooms, bathrooms, kitchens, utility rooms, residential and commercial facilities.

product information

SCE LV range



Product Code	Description
SCE100LV	Basic unit, fan only
SCE100TLV	Run on timer unit
SCE100HLV	Humidistat unit plus timer with neon light

Product Code	Voltage	Maximum Volume		Mounting Arrangement			Operation					
		l/sec	m ³ /hr	Ceiling	Wall	Ducting	Fan Only	Pull Cord	Run on Timer	Electric Shutter	Humidistat	PIR
SCE100LV	12	36	130	√	√	√	√					
SCE100TLV	12	36	130	√	√	√	√		√			
SCE100CLV	12	36	130	√	√	√	√				√	

dimensional data

SCE LV range

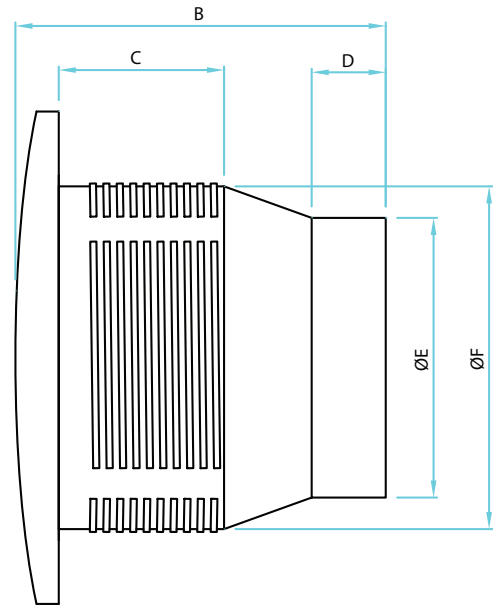
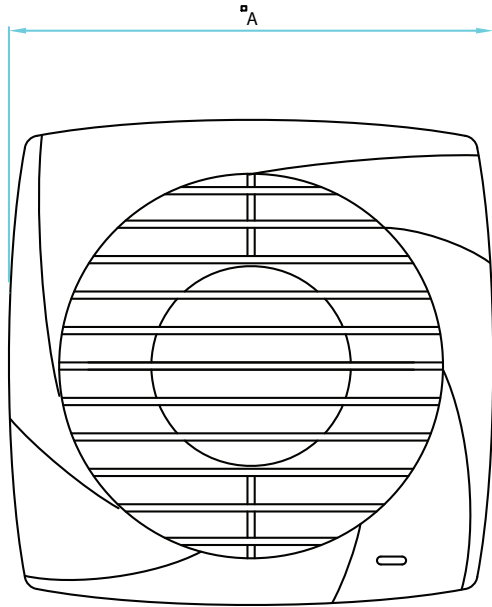

Product Code	A	B	C	D	E	F	Weight kg
SCE100LV	190	130	58	26	98	148	2.0

SCE LV range

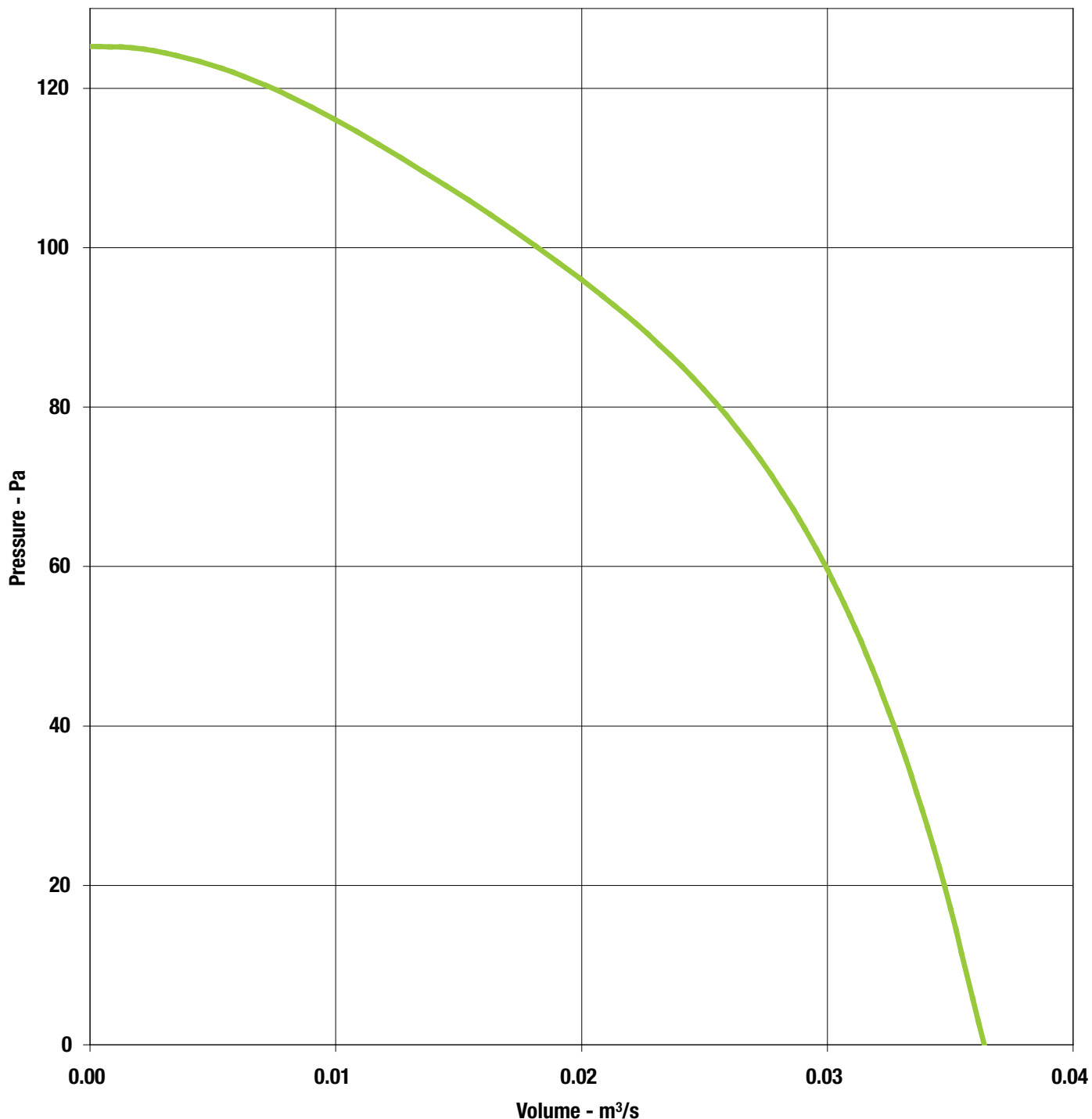

Model	SCE100LV
Diameter.	100mm
Volts.	12*
Watts.	30
r/min	2100
l/sec.	36
Max Pa.	123
dBA @ 3m	49

* Supplied through a transformer operating outside the room on 230V

flexible wall sleeve kit



- Comprises durable white plastic grille for external mounting
- 3 metres of pvc flexible duct

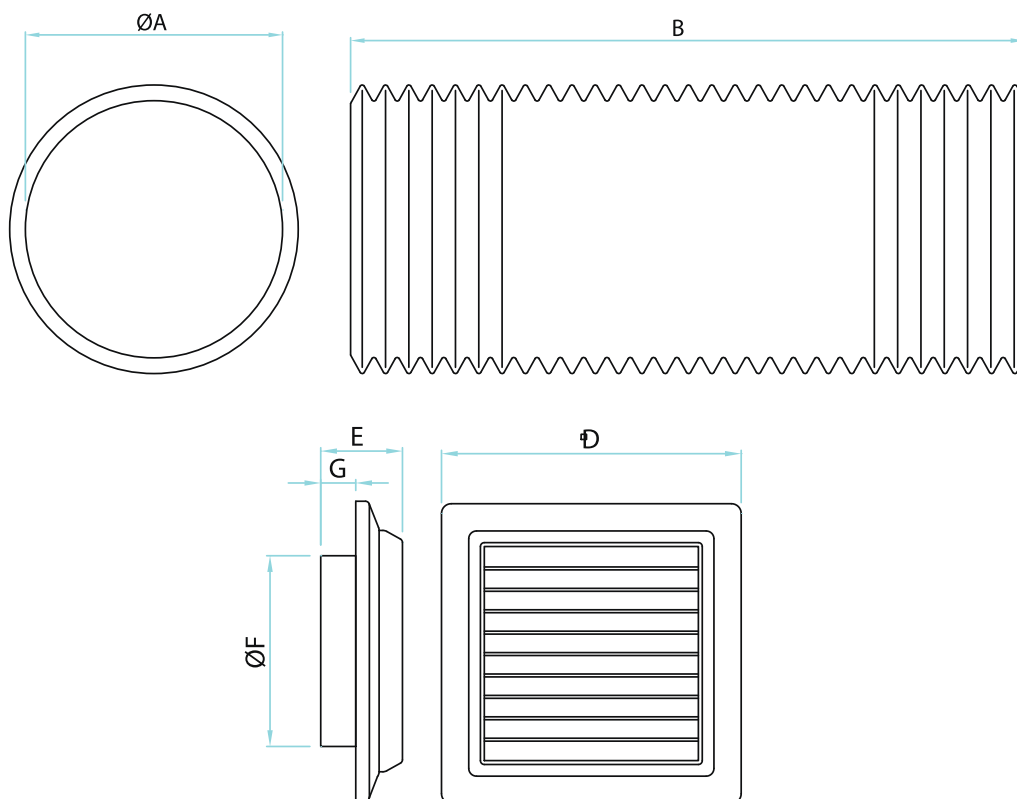

Product Code		A	B	Weight kg		D	E	F	G	Weight kg
SK100SAWKFlex	FLEX 100	100	356	0.305	GRILLE 100	154	42	98	18	0.114
SK125SAWKFlex	FLEX 125	125	356	0.385	GRILLE 125	200	58	123	28	0.210
SK150SAWKFlex	FLEX 150	150	356	0.474	GRILLE 150	200	58	148	28	0.210

accessories

external wall grille



- Durable white plastic
- Mounted independantly of fan

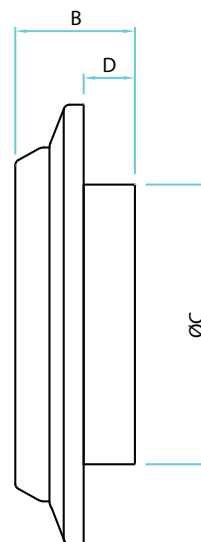
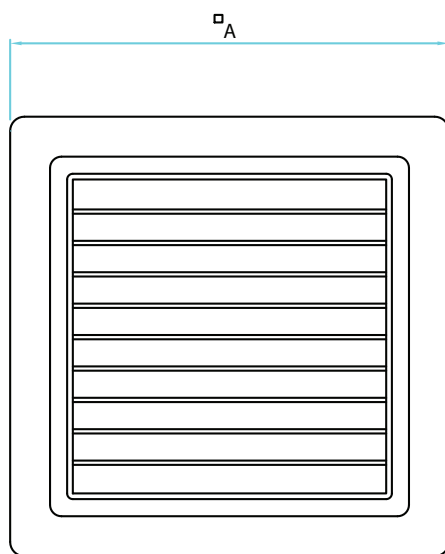

Product Code	A	B	C	D	Weight kg
SKGW-100D	154	42	98	18	0.114
SKGW-125D	200	58	123	28	0.210
SKGW-150D	200	58	148	28	0.210

fan locking ring

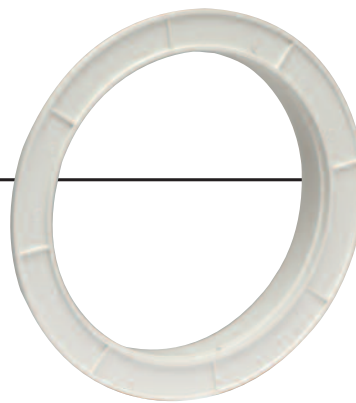

- Durable white plastic
- Fits directly to fan allowing easy installation without fixing screws

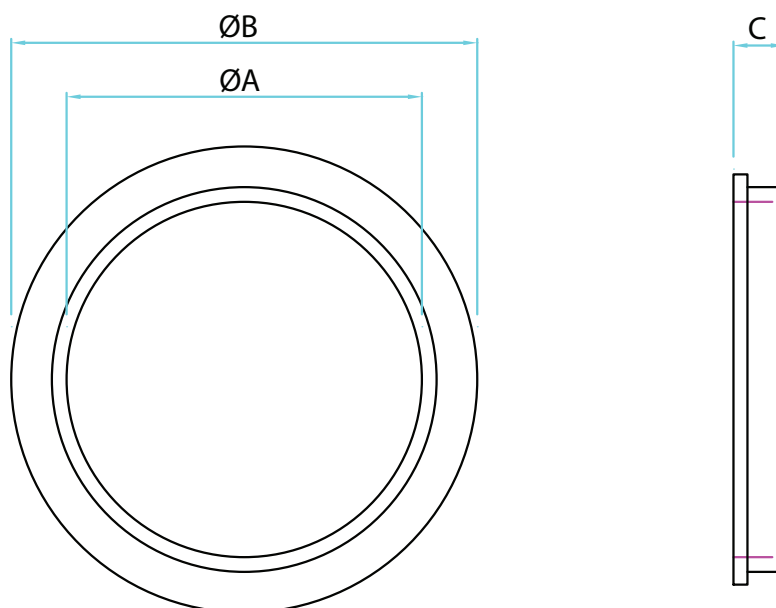

Product Code	A	B	C	Weight kg
SK100SACR	100	132	15	0.048
SK125SACR	125	155	26	0.075
SK150SACR	150	187	26	0.100



- Durable white plastic
- Opens automatically with airflow
- Mounted independently of fan

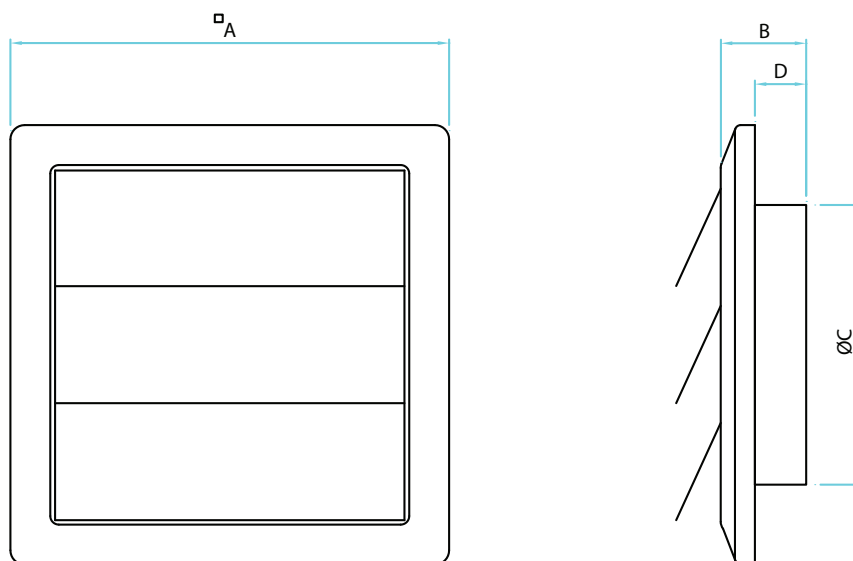

Product Code	A	B	C	D	Weight kg
SKFLW-100D	154	42	98	18	0.078
SKFLW-125D	200	58	123	28	0.178
SKFLW-150D	200	58	148	28	0.182

accessories

telescopic kit



- Durable white plastic grille for external mounting and rigid, white plastic telescopic sleeve.
- Minimum length of 215mm and maximum length of 380mm

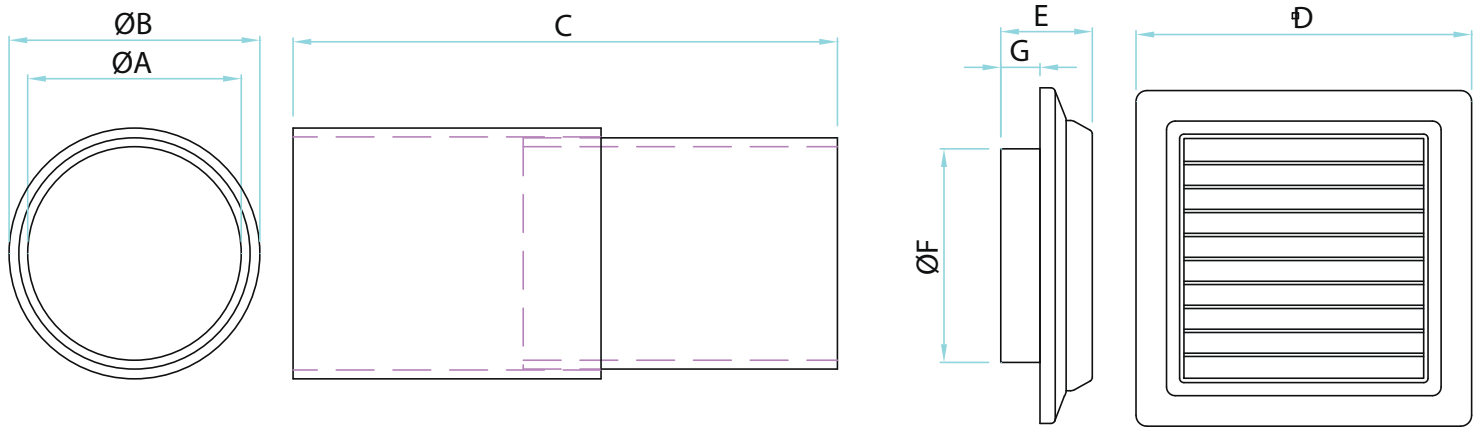

Product Code		A	B	C	Weight kg		D	E	F	G	Weight kg
SK100SAWKTLSCOP	SLEEVE 100	100	105	203/355	0.305	GRILLE 100	154	42	98	18	0.114
SK125SAWKTLSCOP	SLEEVE 125	125	130	203/355	0.385	GRILLE 125	200	58	123	28	0.210
SK150SAWKTLSCOP	SLEEVE 150	150	155	203/355	0.474	GRILLE 150	200	58	148	28	0.210

accessories

backdraught shutter



- Durable white plastic
- Opens automatically with airflow
- Mounts directly to fan outlet

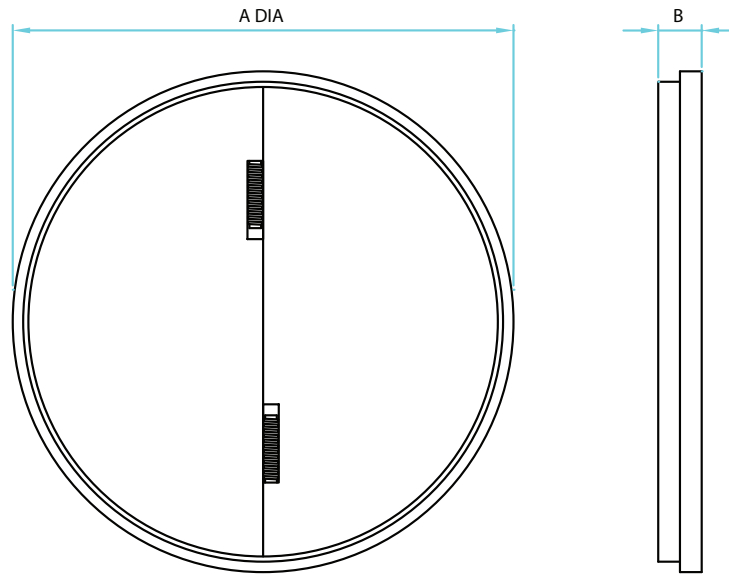

Product Code	A	B	Weight kg
SK100-SEBDS	150	50	0.014
SK125-SEBDS	180	62	0.018

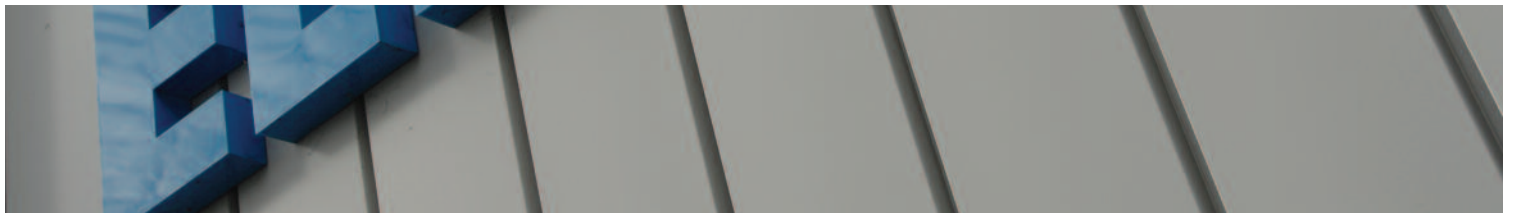

Elta Fans Ltd - Applied Technology

17 Barnes Wallis Road,
Segensworth East Industrial Estate,
Fareham, Hampshire, P015 5ST, United Kingdom.

Visit: eltafans.com

e-mail: mailbox@eltafans.co.uk

Applied Technology:

Tel: +44 (0) 1489 566500

Fax: +44 (0) 1489 566555

Building Services:

Tel: +44 (0) 1384 275800

Fax: +44 (0) 1384 275810

Export:

Tel: +44 (0) 1489 566500

Fax: +44 (0) 1489 566555